



TECH SPECS



BOLDUC

[Tech Spec Home](#)
[Table of Contents](#)
[Contact Us](#)

ICPI TECH SPEC NUMBER • 10

Application Guide for Interlocking Concrete Pavements

This technical bulletin provides an overview of interlocking concrete pavements for a range of applications. The Interlocking Concrete Pavement Institute (ICPI) publishes other technical bulletins, brochures, design manuals, and software that address many of the applications in greater detail.

© 1999 ICPI Tech Spec No. 10 Interlocking Concrete Pavement Institute—Revised March 2003

Interlocking concrete pavements are typically constructed as flexible pavements on a compacted soil subgrade and compacted aggregate base.

Product Description

Applications: Interlocking concrete pavements are appropriate for any application that requires paving. These areas include patios, driveways, pool decks, sidewalks, parking lots, pedestrian plazas, roof plaza decks, roof ballast, roof parking decks, embankment stabilization, gas stations, medians, streets, industrial pavements, ports, and airports.

Composition and Materials: Interlocking concrete pavers are composed of portland cement, fine and coarse aggregates. Color is often added. Admixtures are typically placed in the concrete mix to reduce efflorescence. These materials are combined with a small amount of water to make a "zero slump" concrete. Pavers are made in factory-controlled conditions with machines that apply pressure and vibration. The result is a consistent, dense, high strength concrete that can be molded into many shapes. Special surface finishes can be produced to give an upscale architectural appearance. These include unique aggregates, colors, tumbling, shot blasting, bush hammering, and polishing.

Technical Data

Physical Characteristics: When manufactured in the U.S., interlocking concrete pavers made by ICPI members typically meet the requirements in ASTM C 936, Standard Specifications for Solid Interlocking Concrete Paving Units. Concrete pavers produced by Canadian ICPI members typically conform to the standard published by the Canadian Standards Association, CSA-A231.2, Precast Concrete Pavers. ICPI offers certification of test results to help ensure that the products meet applicable ASTM or CSA standards.

Applications Standards: For pedestrian applications and residential driveways, 2 3 / 8 in. (60 mm) thick pavers are recommended. Pavements subject to vehicular traffic typically require pavers that are 3 1 / 8 in. (80 mm) thick. Units with an overall length to thickness (aspect) ratio greater than 4 should not be used in vehicular applications. Those with aspect ratios between 3 and 4 may be used in areas with limited vehicular use such as residential driveways. Units with aspect ratios of 3 or less are suitable for all vehicular applications. Interlocking concrete pavements are typically constructed as flexible pavements on a compacted soil subgrade and compacted aggregate base. Concrete pavers are then placed on a thin layer of bedding sand (1 to 1 1 / 2 in. or 25 to 40 mm), compacted, sand swept into the joints, and the units compacted again. When compacted, the pavers interlock, transferring vertical loads from vehicles to surrounding pavers by shear forces through the joint sand. The sand in the joints enables applied loads to be spread in a manner similar to asphalt, reducing the stresses on the base and subgrade.

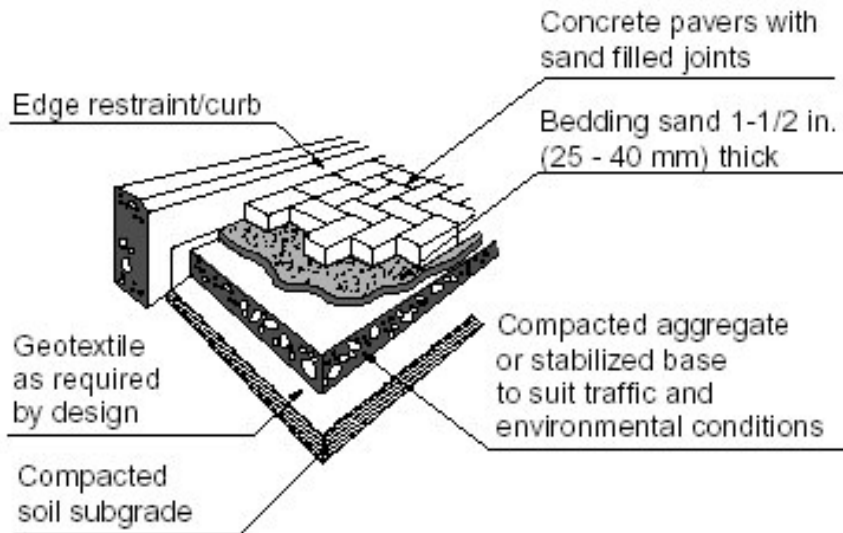
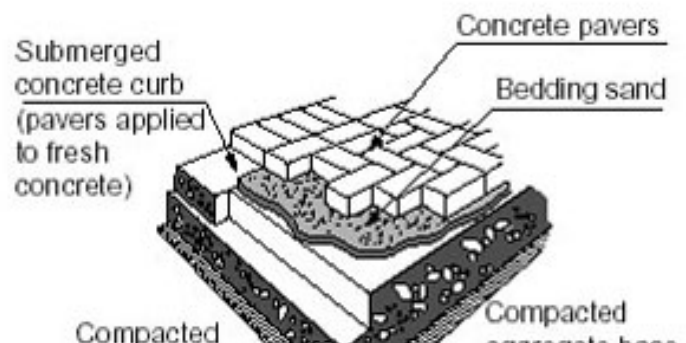
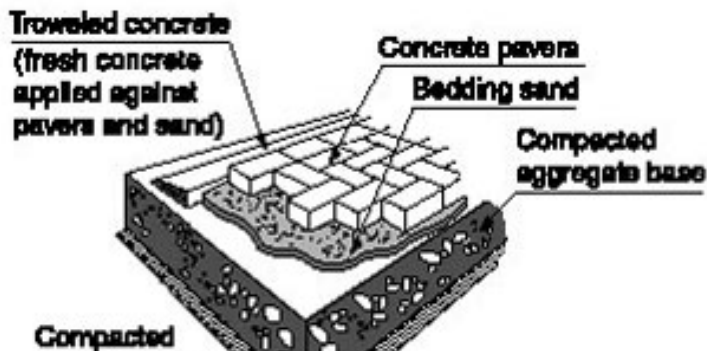
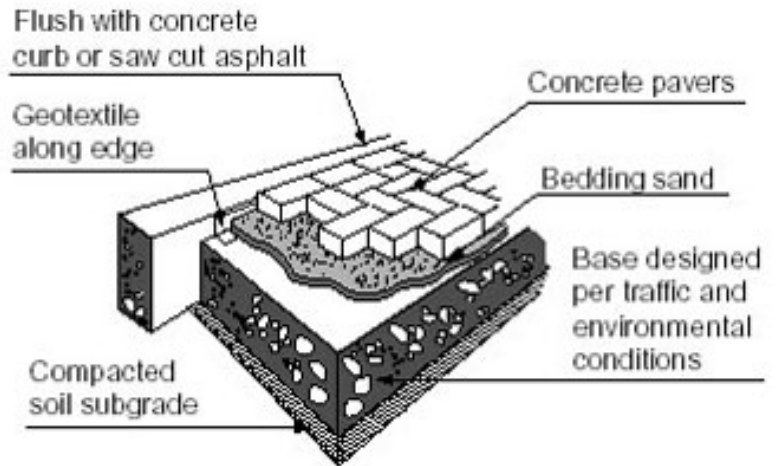
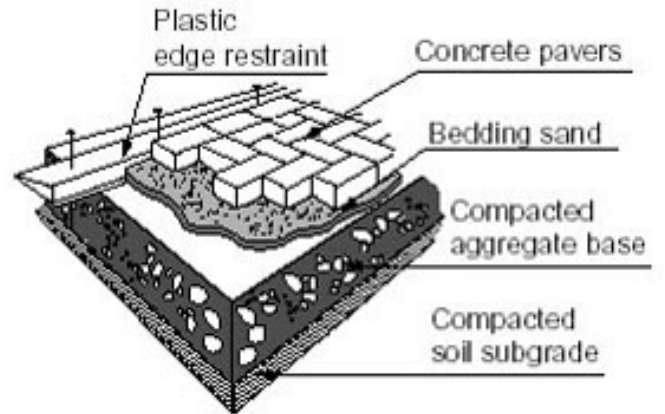
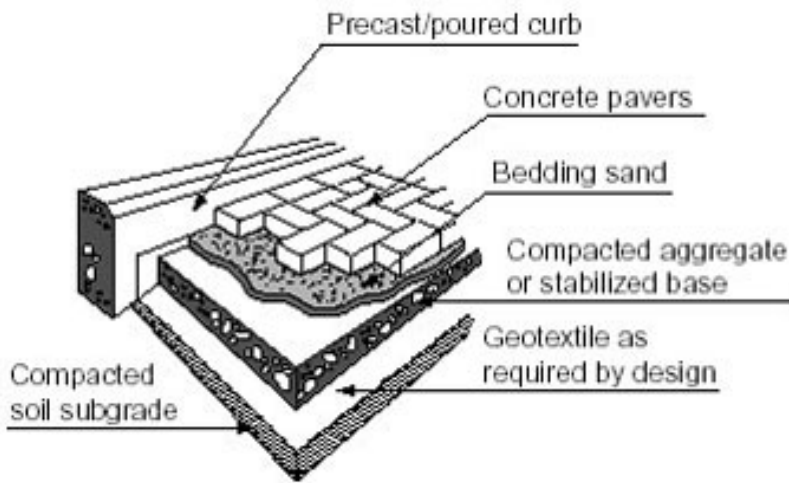

Figure 1. Typical components of an interlocking concrete pavement system.



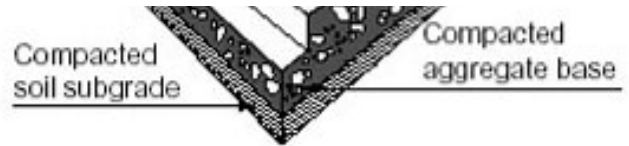

Figure 2. Edge Restraints. Note: Troweled concrete and submerged concrete curbs are recommended in non-freeze thaw areas only.

Benefits: As interlocking concrete pavements receive traffic, they stiffen and increase their structural capacity over time. *The structural contribution of the interlocking pavers and sand layer can exceed that of an equivalent thickness of asphalt.* The interlock contributes to the structural performance of the pavement system. ICPI *Tech Spec 4* provides additional information on structural design of the pavers, sand, and base. Concrete pavers do not require time to cure. They arrive at the site ready to install, ready for traffic immediately after paving. This can reduce construction time and restore access quickly. The joints between each paver eliminate cracking normal to conventional asphalt and concrete pavement. Unlike concrete or asphalt, concrete pavers do not rely on continuity of their material for structural integrity. Therefore, utility cuts can be reinstated without damage to the pavement surface. Repair to underground utilities and to local deformations in the base materials can be accessed by removing and later reinstating the same pavers. No pavement materials are wasted or hauled to the landfill. Jackhammers are not required to open interlocking pavements. The modular units enable changes in the layout of the pavement over its life. Colored units can be used for lane and parking delineations, traffic direction markings, utility markings, and artistic super graphic designs. Various colors, shapes, and laying patterns can support control and direction of pedestrian or vehicular traffic, and can be used as detectable warnings on pedestrian ramps at intersections. The chamfered joints in the pavement surface facilitate removal of surface water. This decreases nighttime glare when wet and enhances skid resistance. Pedestrian slip resistance meets or exceeds guidelines recommended in the Americans with Disabilities Act (ADA). ICPI *Tech Spec 13* includes further information on slip and skid resistance of concrete pavers. Snow is removed as with any other pavement. Concrete pavers have greater resistance to deicing salts than conventional paving materials due to high cement content, strength, density, and low absorption.

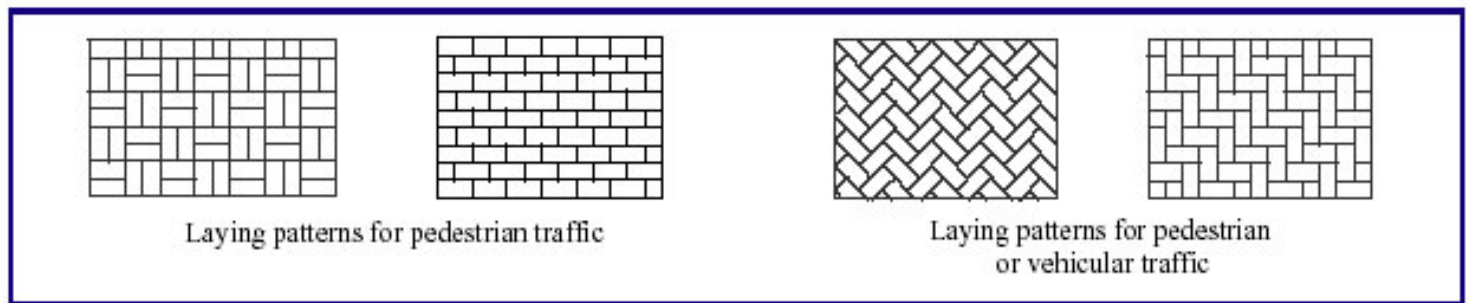

Figure 3. Typical laying patterns.

Installation

It is recommended that installation be performed by experienced contractors who hold a current certificate in the ICPI Concrete Paver Installer Certification Program. Contractors holding this certificate have been instructed and tested on knowledge of interlocking concrete pavement construction. Interlocking concrete pavements typically consist of a soil subgrade, an aggregate base, bedding sand, concrete pavers, edge restraints, and drainage (see Figure 1). Geotextiles are sometimes used under the base, over fine, moist subgrade soils to extend the life of the base and reduce the likelihood of deformation. The installation guidelines below apply to pedestrian and many vehicular applications. For street, industrial, port and airport pavement designs, consult with a qualified civil engineer familiar with local soils, pavement design methods, ICPI resources for these applications, materials, and construction practices. ICPI also has information on design, construction, and maintenance of permeable interlocking concrete pavements for control of runoff and nonpoint storm water pollution.

Soil Subgrade: Once excavation has been complete, the soil subgrade should be compacted prior to placing the aggregate base. Compaction should be at least 98% Proctor density (per ASTM D 698) for pedestrian areas and residential driveways, and at least 98% modified Proctor density (per ASTM D 1557) for areas under constant vehicular traffic. Consult compaction equipment manufacturers' recommendations for applying the proper equipment to compact a given soil type. Some soils may not achieve these recommended minimum levels of density. These soils may have a low bearing capacity or be continually wet. If they are under a base that will receive constant vehicular traffic, the soils may need to be stabilized, or have drainage designed to remove excess water.

Aggregate Base: Aggregate base materials should conform to that used under asphalt. If no local, state, or provincial standards exist,

then the requirements for aggregate base in ASTM D 2940 are recommended. The base should be compacted in 6 in. (150 mm) maximum lifts. The thickness of the base depends on the strength of the soil, drainage, climate, and traffic loads. Base thickness used under asphalt can typically be used under interlocking concrete pavers. Minimum aggregate bases for walks should be 4 to 6 in. (100 to 150 mm), driveways 6 to 8 in. (150 to 200 mm), and streets 8 to 12 in. (200 to 300 mm). Thickness may be adjusted depending on site conditions and traffic. Compaction of the aggregate base under pedestrian and residential driveway pavements should be at least 98% of standard Proctor density (per ASTM D 698). The aggregate base should be compacted to at least 98% modified Proctor density (per ASTM D 1557) for vehicular areas. Compaction equipment suppliers can provide information on the appropriate machines for compacting base material. These density recommendations for areas next to curbs, utility structures, lamp bases, and other protrusions in the pavement are essential to minimize settlement. Site inspection and testing of the compacted soil and base materials are recommended to ensure that compaction requirements have been met. Compacted base materials stabilized with asphalt or cement may be used in heavy load applications or over weak soil subgrades. The surface of the compacted base should be smooth with a maximum tolerance of $\pm 3 / 8$ in. (10 mm) over a 10 ft. (3 m) straight-edge.

Bedding Sand: Bedding sand should conform to the grading requirements of ASTM C 33 or CSAA23.1-FA1. Do not use mason sand. Stone dust or waste screenings should not be used, as they can have an excessive amount of material passing the No. 200 (0.075 mm) sieve. The sand should be screeded to an even thickness of 1 in. to 1 1 / 2 in. (25-40 mm). Do not use the sand to fill depressions in the base. These eventually will be reflected in the surface of the finished pavement. Fill any depressions with base material and compact. Geotextile may be applied under the bedding sand in certain places. These areas are adjacent to curbs, roof parapets, drains, utility structures, and over asphalt or cement stabilized bases to prevent migration of the bedding sand into joints or cracks. When applied in these locations the fabric should be turned up against vertical surfaces to contain the bedding sand.

Joint Sand: Bedding sand may be used as joint sand, however, extra time and effort may be required in sweeping and forcing the sand between the pavers. For that reason, fine, dry sand may be used that conforms to the grading requirements of ASTM C144 or CSA-A179. This sand is often called mason sand and is used to make mortar. This sand should not be used for bedding sand.

Concrete Pavers: The shape of the concrete pavers determines the range of laying patterns (Figure 3). 45 ° to 90 ° herringbone patterns are recommended in areas subject to continual vehicular traffic. They will give the maximum interlock and structural performance. Some patterns have "edge" pavers specifically designed to fit against the edge restraints. Concrete pavers can be cut with a splitter or masonry saw to fit along the edge of the pavement. For streets and industrial areas exposed to tire traffic pavers should be no smaller than one-third of a unit along the edge of the pavement. Once the pavers are placed in their specified pattern(s), they are compacted into the bedding sand with a plate compactor. The compactor should have a minimum force of 5,000 lbs. (22 kN) and frequency of 75 to 100 hz. After the pavers are compacted, sand is swept and vibrated into the joints until they are full. All pavement within 3 ft (1 m) of unfinished edges should have the joints full and be compacted at the end of each day. See *ICPI Tech Spec 2* for further information on construction. *ICPI Tech Spec 9* provides a guide specification for installation.

Edge Restraints: Edge restraints around interlocking concrete pavement are essential to their performance (Figure 2). The pavers and sand are held together by them, enabling the system to remain interlocked. For walks, patios, and driveways, edge restraints can be steel, aluminum, troweled concrete and submerged concrete curb, or plastic edging specifically designed for concrete pavers. Concrete restraints are recommended for crosswalks, parking lots, drives, streets, industrial, port, and airport pavements. Precast concrete and cut stone curbs are suitable for streets, drives, and parking lots. Edge restraints are typically placed before installing the bedding sand and concrete pavers. Some edge restraints such as plastic, steel, and aluminum can be installed after placing the concrete pavers. See *ICPI Tech Spec 3* for further information on edge restraints.

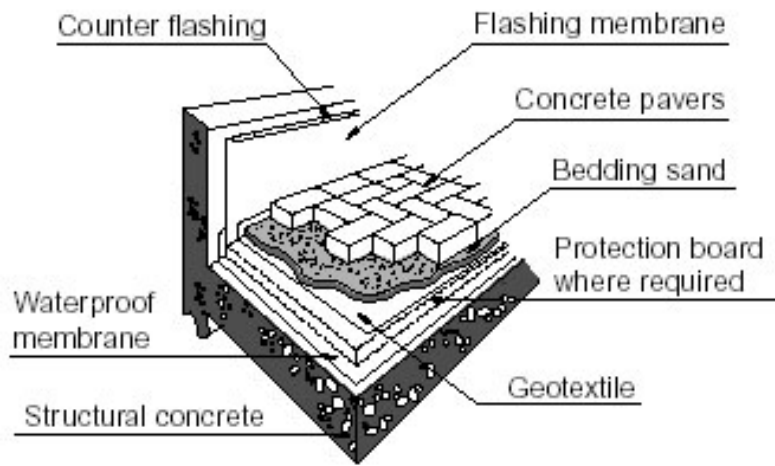

Figure 4. Roof assembly.

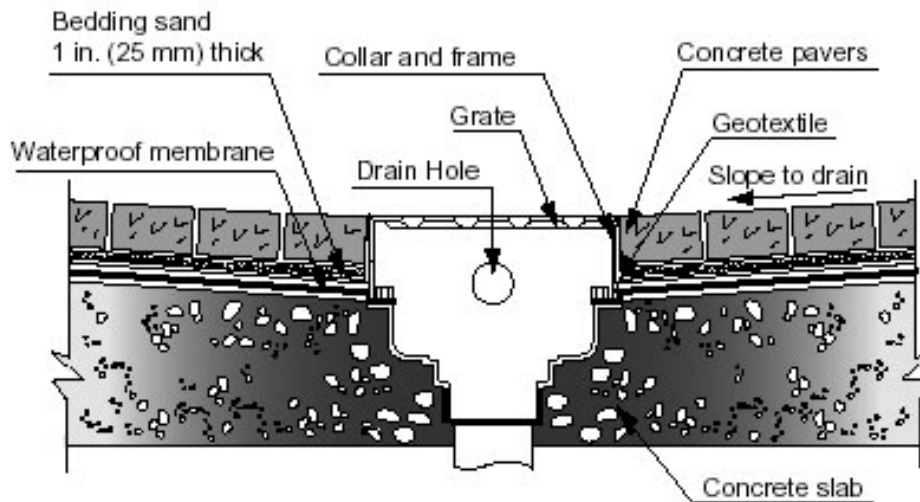

Figure 5. Roof drain with drain holes at bottom of bedding sand layer.

Drainage: Surface and subsurface drainage systems, as well as pavement grades, should conform to that used for any other flexible pavement.

Swimming Pools: High slip-resistance and rapid drainage of water make concrete pavers a desirable surface around commercial or residential swimming pools. The pavers and bedding sand can be placed on a compacted aggregate or concrete base. If placed on a concrete base, drain holes are necessary at the lowest elevations to remove excess moisture in the bedding sand. A urethane or neoprene sealant and backer rod should be placed between the course of pavers and the pool coping. Sealing the pavers and joints is recommended.

Roof Plaza/Parking Decks: Interlocking concrete pavements can be placed on parking garage roofs and pedestrian roof plazas. Concrete pavers provide an attractive ballast for the waterproof membrane (Figure 4). As a heat sink, the pavers reduce thermal stress on the membrane. The roof structure should be waterproofed, designed to withstand loads, and be sloped at least 2% to drain. Protection board should be applied according to the recommendations of the waterproof membrane manufacturer. Geotextile is applied around roof drains to prevent the migration of bedding sand. The drains should have holes at the level of the waterproof membrane to allow removal of subsurface water (Figure 5). See *Tech Spec 14* for further information on roof plaza deck applications.

Gas Stations: For new and refurbished gas stations, concrete pavers provide a safe, oil and fuel-resistant surface. When concrete pavers are removed for repairs to underground power lines, pipes, and storage tanks, they can be reinstated with no ugly patches or time wasted for curing. Stabilized bases are recommended under the pavers and bedding sand to withstand loads from fuel trucks or other heavy vehicles. After installation of the base, bedding sand, concrete pavers, and joint sand, a liquid, fuel-resistant sealer should be applied to and allowed to soak into the joints. Upon curing, the sealer reduces the likelihood of infiltration of petroleum products

from drippings and occasional minor spills.

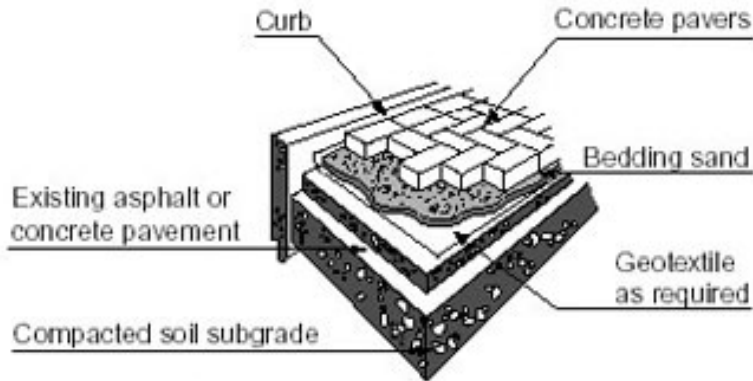

Figure 6. Typical overlay/inlay on existing pavement.

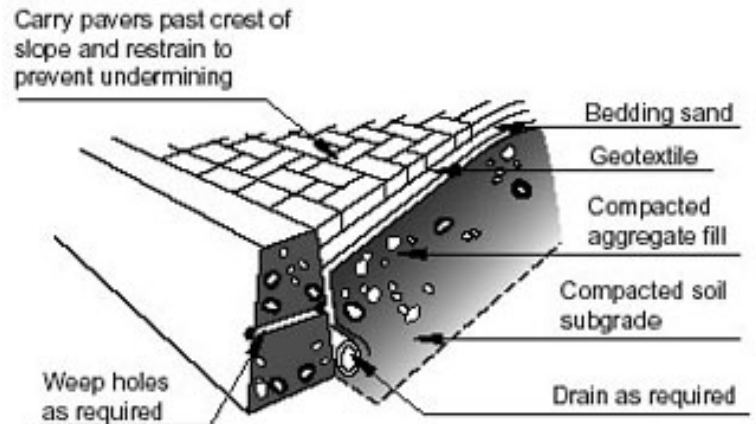

Figure 7. Embankment with concrete pavers.

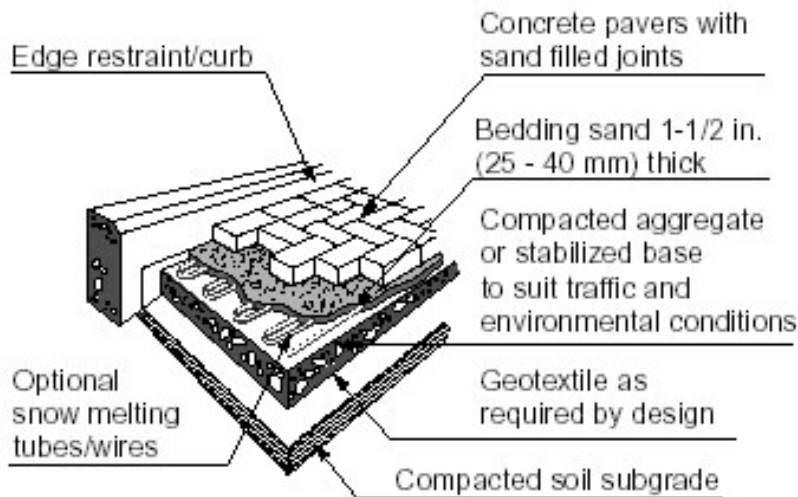

Figure 8. Snow melting system with concrete pavers.

Pavement Overlay/Inlay: New or existing asphalt or concrete pavements can be overlaid or inlaid with concrete pavers (Figure 6). The surface of the existing pavement can be ground out and bedding sand and pavers placed in the milled area. Considerations should be given to drainage of excess moisture in the bedding sand during the early life of the pavement overlay/inlay. Drainage can be achieved by drilling/ casting vertical holes at the lowest elevations of the pavement, or directing drain holes to catch basins. The drain holes should be covered with geotextile to prevent loss of bedding sand. Geotextile may need to be applied at pavement joints and cracks. Cracks 3 / 8 in. (10 mm) or larger in width should be patched prior to placing geotextile, bedding sand, and pavers.

Embankments and Vehicular Pavements with High Slopes: Pavers provide a durable surface for control of soil erosion from embankments. A backfill of open-graded aggregate with drains at the bottom of the slope is recommended to relieve hydrostatic pressure (Figure 7). Concrete pavers restrained at the sides and top of the slope should have adjacent areas graded and slope in such a manner that water runs away from the restraints. Vehicular pavements with slopes over 8% may require concrete header beams. The presence and spacing of beams is subject to the designer's discretion. Drainage of water in the bedding sand and base is essential along the upslope side of the concrete headers. For concrete pavers and bedding sand over aggregate base, removal of water can be accomplished with prefabricated geocomposite drains. When pavers and bedding are over concrete or asphalt, there should be several geotextile-covered drain holes in these pavements on the upslope side of the header. The water collected by these drain holes or geocomposite drains should be directed beyond the edge restraints of the pavement. The overall dimensions of, and the steel reinforcement within the concrete headers will depend upon traffic loads and base design. Minimum recommended dimensions are 6 in. (150 mm) wide and 12 in. (300 mm) deep. The joint sand between the pavers should be stabilized with a sealer to prevent washout. The crossfall of the pavement should be at least 2% from the center.

Snow Melting Systems: Interlocking concrete pavements can accommodate snow melting systems for pedestrian and vehicular

applications (Figure 8). The systems consist of hot, liquid-filled tubing or radiant wires placed in the bedding sand, in compacted aggregate concrete, or asphalt base. Snow melt systems turn on automatically when a snowstorm starts, eliminating plowing, ice hazards, and the need for de-icing salts. The result is less potential for injuries from slipping on ice and decreased liability. An aggregate base can be used to support the tubing or wires for pedestrian areas and residential driveways. Both systems must be secured to the base prior to placing the bedding sand. The systems are installed by specialty contractors (electricians and/or plumbers). The bedding sand may be as much as 2 in. (50 mm) thick to cover and protect the tubing or wires. For other vehicular areas, the tubing or wires should be in placed in a concrete or asphalt base. See *ICPI Tech Spec 12* for further information on snow melting systems.



Figure 9. Mechanical installation equipment places concrete pavers rapidly.

Rigid Pavements: Construction of rigid pavements is slower and more expensive compared to sand-set installations. Concrete pavers can be set on a sand-asphalt setting bed with neoprene modified asphalt mastic. The base under the asphalt is typically concrete. Joints are filled with sand, and may also be filled with cement-stabilized sand. Caution should be taken in preventing the pavers from becoming stained by the cement in the sand. Bitumen-set pavers can be placed in vehicular areas. Attention should be given to draining excess water from the base supporting the bitumen setting bed. While bitumen-set concrete pavers perform adequately, the preferred setting bed is sand. Bitumenset concrete pavers will increase the cost of the installation when compared to sand set installations. This installation method requires a concrete base and additional costs from handling the asphalt setting bed and mastic. Small areas are installed in the following sequence. A prime coat is placed on a concrete base, the asphalt bed is placed, screeded, and then compacted. Mastic is applied to the bed and the pavers are placed on it. Should the surface of the pavers be stained with mastic, it is very difficult to remove. Reinstatement of bitumen-set pavers is impossible because the asphalt material adheres to the bottom of the pavers when removed. It is less expensive to discard the pavers rather than remove the asphalt from the units and attempt to reinstate them. Bitumen-set concrete pavers are not recommended on asphalt or aggregate bases. Pavers can be mortared directly to a concrete base using an acrylic fortified mortar bed. Mortared applications work best in pedestrian areas in non-freezethaw regions. Polymer adhesives specially designed for adhering concrete pavers to concrete enable faster installation without the chance of accidentally staining the surface of the pavers with mortar. These adhesives can be used in areas with freezing climates. Mortared pavers and those set with adhesives are not recommended for vehicular areas.

Mechanical Installation: Certain laying patterns can be installed mechanically, saving construction time. Specialized installation equipment enables over a square yard (m²) of concrete pavers to be placed in succession, rather than one paver at a time (Figure 9). Contact a local ICPI supplier for availability of laying patterns and for contractors experienced with mechanical installation equipment. See *ICPI Tech Spec 11 and 15* for further information on mechanical installation.

Availability and Price

Availability: Interlocking concrete pavers are available from ICPI members throughout the U.S. and Canada. Check with a local member for available shapes, thicknesses, and colors.

Price: Prices will vary depending on the site location, pattern, thickness, color, area, base requirements, edge restraints, and drainage.

Warranty

ICPI paver suppliers will typically certify that the specified product meets the requirements of ASTM C 936 or CSA A231.2 as

applicable. It is recommended that the manufacturer have a current product certification from ICPI. This certifies that concrete pavers submitted by the manufacturer to an independent testing laboratory passed applicable ASTM or CSA tests.

Maintenance

When properly installed, interlocking concrete pavements require practically no maintenance. As with all pavements, they will become soiled over time depending on the amount of use. Contact a local ICPI supplier for information on cleaning concrete pavers. ICPI publishes other technical bulletins on cleaning, sealing, (ICPI *Tech Spec 5*) and reinstatement of concrete pavers (ICPI *Tech Spec 6*).

Interlocking Concrete Pavement Institute
13921 Park Center Road, Suite 270
Herndon, VA 20171 USA
Phone: (703) 657-6900
Fax: (703) 657-6901



In Canada:
PO Box 85040
561 Brant Street
Burlington, ON L7R 4K2
CANADA

e-mail: icpi@icpi.org
Web Site: www.icpi.org

WARNING: *The content of ICPI Tech Spec Technical Bulletins is intended for use only as a guideline. It is NOT intended for use or reliance upon as an industry standard, certification or a specification. ICPI makes no promises, representations or warranties of any kind, express or implied, as to the content of the Tech Spec Technical Bulletins and disclaims any liability for damages resulting from the use of Tech Spec Technical Bulletins. Professional assistance should be sought with respect to the design, specifications and construction of each project.*